



# A Series Lithium-ion Walkie Pallet Jack

with capacities of 5,000lbs



**HANGCHA**

**HC FORKLIFT AMERICA CORPORATION**

**Company address:**

10405-A Granite Street  
Charlotte, NC 28273

Toll Free: (888) 652-8395

Phone: (980) 888-8335

Fax: (980) 888-8336

[america@hcforklift.com](mailto:america@hcforklift.com)

[www.hcforkliftamerica.com](http://www.hcforkliftamerica.com)



ISO9001:2015



ISO14001:2015

2021 VERSION / COPYRIGHT 2021

HANGCHA GROUP CO., LTD. reserves the right to make any changes without notice concerning colors, equipment, or specifications detailed in this brochure, or to discontinue individual models. The colors of trucks, delivered may differ slightly from those in brochures.

***Making Material Handling Easier***  
SINCE 1956



# SMOOTHER TOUGHER MANEUVERABLE

The A Series Lithium-ion Walkie Pallet Jack is a new logistics handling device developed by Hangcha Group for the high-intensity operating conditions of the North American market. With the AC drive technology, it offers high performance and low maintenance costs. It is also safe, reliable, and can be easily operated. This walkie pallet jack with a 4,500lb load capacity is an ideal tool for loading, unloading, and handling palletized goods in warehouses, supermarkets, and workshops.



## Appearance

- / The A Series Lithium-ion Walkie Pallet Truck has a smooth vivid profile and was designed to be ergonomic. The exterior of this forklift is powder coated in a durable, easy to see, green finish that designates it as a lithium-ion powered pallet truck.
- / This pallet truck uses stamped steel plates and injection molded parts. This creates a robust and durable product that is able to successfully take on the wear and tear of a warehouse environment.

## Performance

- / The maintenance-free, high-power, brushless AC traction motor has excellent acceleration, performance, good climbing ability, and low heat generation.
- / The CURTIS control system provides accurate, stable, and more efficient control of the AC traction motor.
- / The CANBUS structure makes the communication between the different parts on the truck faster and more reliable.
- / The truck uses the regenerative braking system to prevent the pallet truck from sliding down a ramp.
- / The switches, controller, connectors, and battery plug are all parts from industry known suppliers to ensure reliability, performance, and ease of service.

## Comfort

- / Thanks to the tiller's design, all operations can be completed with one hand.
- / When in turtle mode, the truck can be driven slow easily, and more accurately.
- / The pallet truck's design is optimized for great visibility and easy operation in narrow aisle applications.

## Safety

- / The power plug is fixed on the truck body to avoid damage when installing the battery.
- / The pallet jack won't slip on a grade to ensure safe operation.
- / When pressed, the emergency button on the tiller head immediately cuts power to the pallet truck to help keep the operator safe.
- / The lifting limit switch is designed to help protect loads from damaging.



The ergonomic tiller head allows for easy operation with one hand.



Features a built-in charger and a maintenance free battery.



The punch-formed forks are stonger. Combined with the tip guides, the truck is durable and efficient.



The battery compartment is conveniently placed for ease of access.



The pallet truck is designed operate over docks, lift gates, and curbs to prevent wear and tear to the carriage and components.

## CATL Lithium Iron Phosphate Battery Packs

- / Integrated Battery Management System (BMS) continually monitors energy management and ensures reliable operation.
- / HANGCHA provides these Lithium Iron Phosphate (LiFePO4) battery packs with a 5 year or 10,000 hour warranty.
- / See warranty certificate for specific warranty information on the Lithium Iron Phosphate battery packs.

Standard Battery Capacity	
Battery Capacity (V/Ah) (kW-h)	24V/125Ah 3.00kW-h
Charger	Built-in (24V/50Ah)

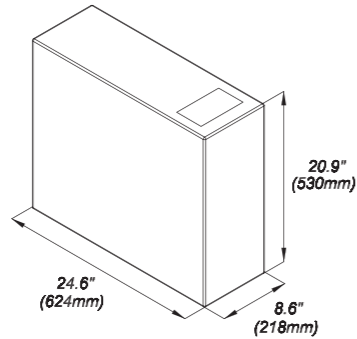

## Reliability

- / With a high-strength steel frame structure, the truck's frame has a large residual load capacity and a long service life.
- / The electrical system uses waterproof connectors and protection on the wires and cables to improve the electronic's reliability.
- / The pump motor has a longer service life and saves energy because of the electronic lifting limit switch on the motor.
- / The low noise and vibration hydraulic power unit enables stable and reliable lifting and lowering.
- / The punched formed forks provide higher strength and are impact resistant.
- / The pallet truck is equipped with tip guides to improve operational efficiency.

## Maintenance

- / The brushless AC drive motor is maintenance-free. This significantly reduces the operating costs of the pallet truck.
- / The integrated battery indicator, hour meter and self-diagnostic instrument are all easy to use.
- / The maintenance hatch opens to allow for easy access to all of the truck's components.
- / The shafts are equipped with lubricated sleeves and oil cups to facilitate maintenance and promote a long service life.

## Standard Specifications

- / 24 Volt Electrical System
- / CAN BUS Communication
- / Curtis AC Controller
- / PU Drive Tire
- / Maintenance-Free Lithium-ion Battery
- / Built-in 50Ah Charger
- / SB-175 Red Battery Connector
- / Battery Disconnect Handle
- / Key Switch
- / Multi-Function Meter
- / Electric Horn
- / Upright-Tiller Creep Speed Feature
- / PU Load Wheel
- / Single Load Wheel
- / Emergency Cut Off Switch

## Options

- / Load Backrest
- / PIN Code Access
- / Rubber Drive Tire
- / Caster Wheels

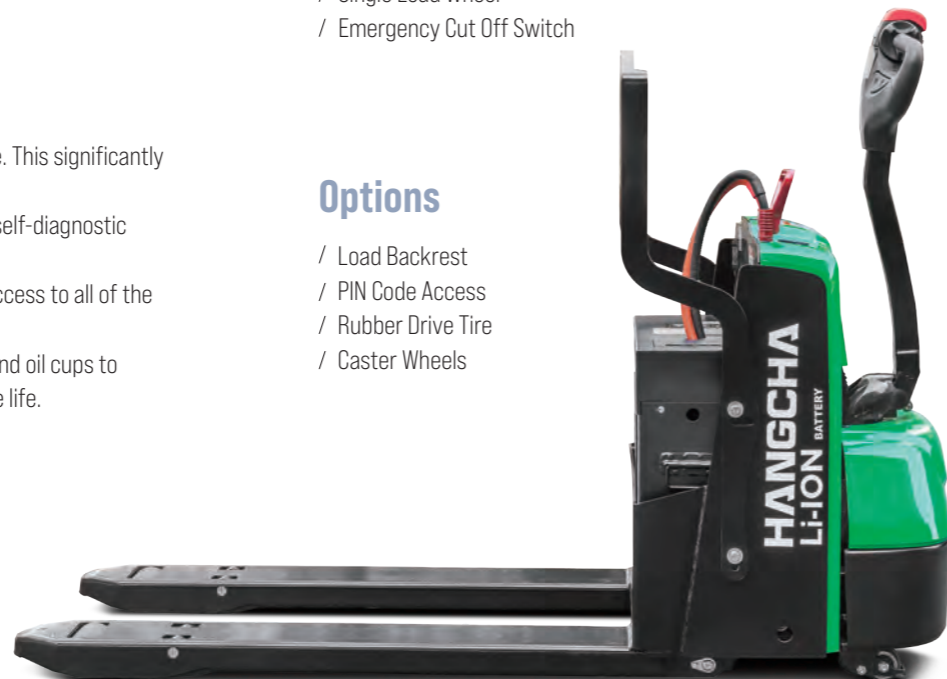

# MORE POWER TO MOVE



# A Series Lithium-ion Walkie Pallet Jack Specification

Distinguishing Marks	1.1	Manufacturer	HANGCHA GROUP CO.,LTD.	
		HCF Model	WP22Li	
	1.2	Manufacturer's Type Designation	CB022-AC1-NAI	
	1.4	Operator Type: hand, pedestrian, standing, seated, order-picker	Walkie	
	1.5	Rated Capacity/Rated Load	Q (lb/kg)	5000/2200
	1.6	Load Centre Distance	c (in/mm)	24/600
	1.8	Load Distance, centre of drive axle to fork	x (in/mm)	39/1000
Weight	2.1	Service Weight Without Battery	lb/kg	795/360
	3.1	Tires: solid rubber, superelastic, pneumatic, polyurethane	PU	
Tires & Chassis	3.2	Tire Size, front	in/mm	Φ9×3/Φ230×75
	3.3	Tire Size, rear	in/mm	Φ3.25×4.5/Φ82.5×114
	3.4	Additional Wheel (dimensions)	in/mm	/
	3.5	Wheels, number front / rear (x = driven wheels)	1x÷/2	
	3.6	Tread, front	b <sub>0</sub> (in/mm)	/
	3.7	Tread, rear	b <sub>1</sub> (in/mm)	20/510
Dimensions	4.4	Lift	h <sub>3</sub> (in/mm)	5.5/140
	4.15	Fork Height, lowered	h <sub>3</sub> (in/mm)	3.35/85
	4.19	Overall Length	l (in/mm)	70/1790
	4.20	Length to Face of Forks	l <sub>2</sub> (in/mm)	25.2/640
	4.21	Overall Width	b (in/mm)	28/710
	4.22	Fork Dimensions	s/e/l (in/mm)	2.36/6.7/45 (60/170/1150)
	4.25	Distance between Fork-Arms	b <sub>s</sub> (in/mm)	27/680
	4.32	Ground Clearance, centre of wheelbase	m <sub>2</sub> (in/mm)	0.9/23
4.35	Turning Radius	Wa (in/mm)	61/1550 <sup>1)</sup>	
Performance Data	5.1	Travel Speed, laden/unladen	mph(kph)	3.7/3.7 (6/6)
	5.2	Lift Speed, laden/unladen	ft/min(m/s)	9/12 (0.045/0.06)
	5.3	Lowering Speed, laden/unladen	ft/min(m/s)	10/8 (0.05/0.04)
	5.8	Max Gradeability, laden/unladen	%	10/16
Electric Motor	6.1	Drive Motor Rating S2 60 min	hp/kW	1.74/1.3
	6.2	Lift Motor Rating at S3 10%	hp/kW	1.6/1.2
	6.4	Battery Voltage, rated capacity	V/Ah	24/125
	8.1	Type of Drive Control	AC	
	9.1	Controller Manufacturer	Curtis	

Note: 1). When fork lowered, +90mm/3.5in

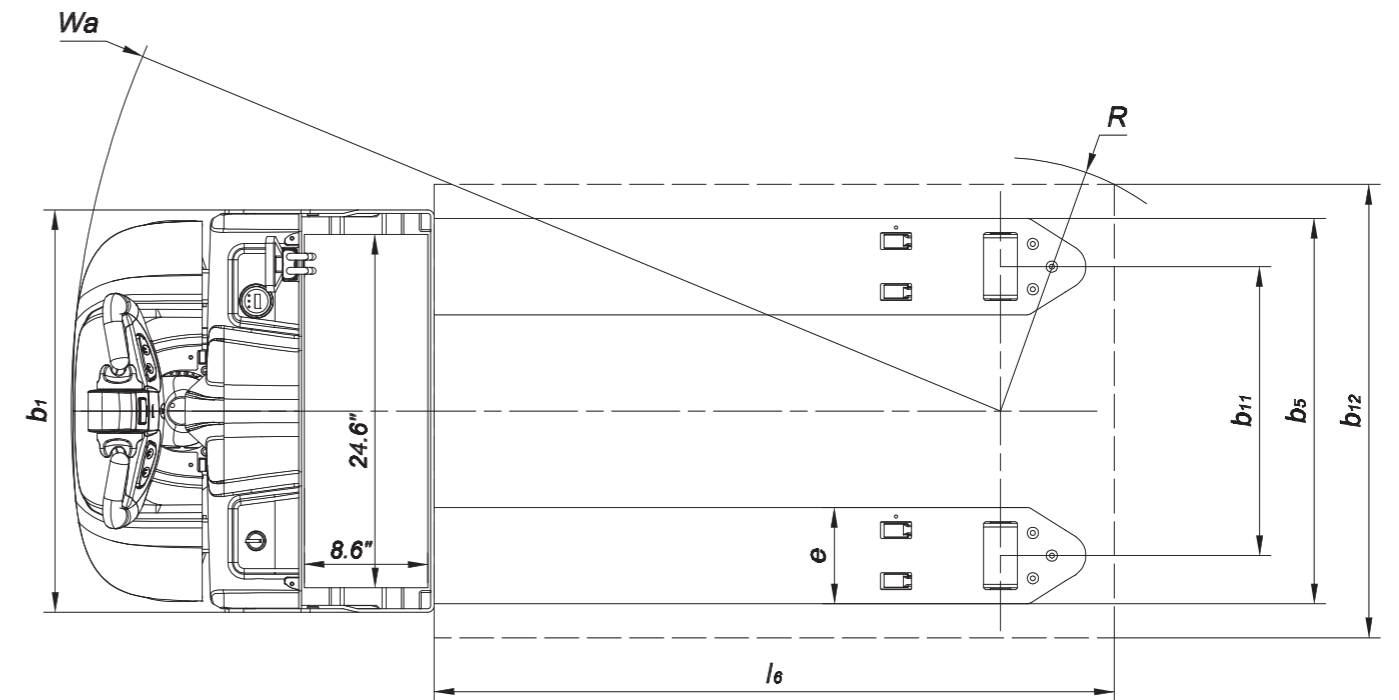
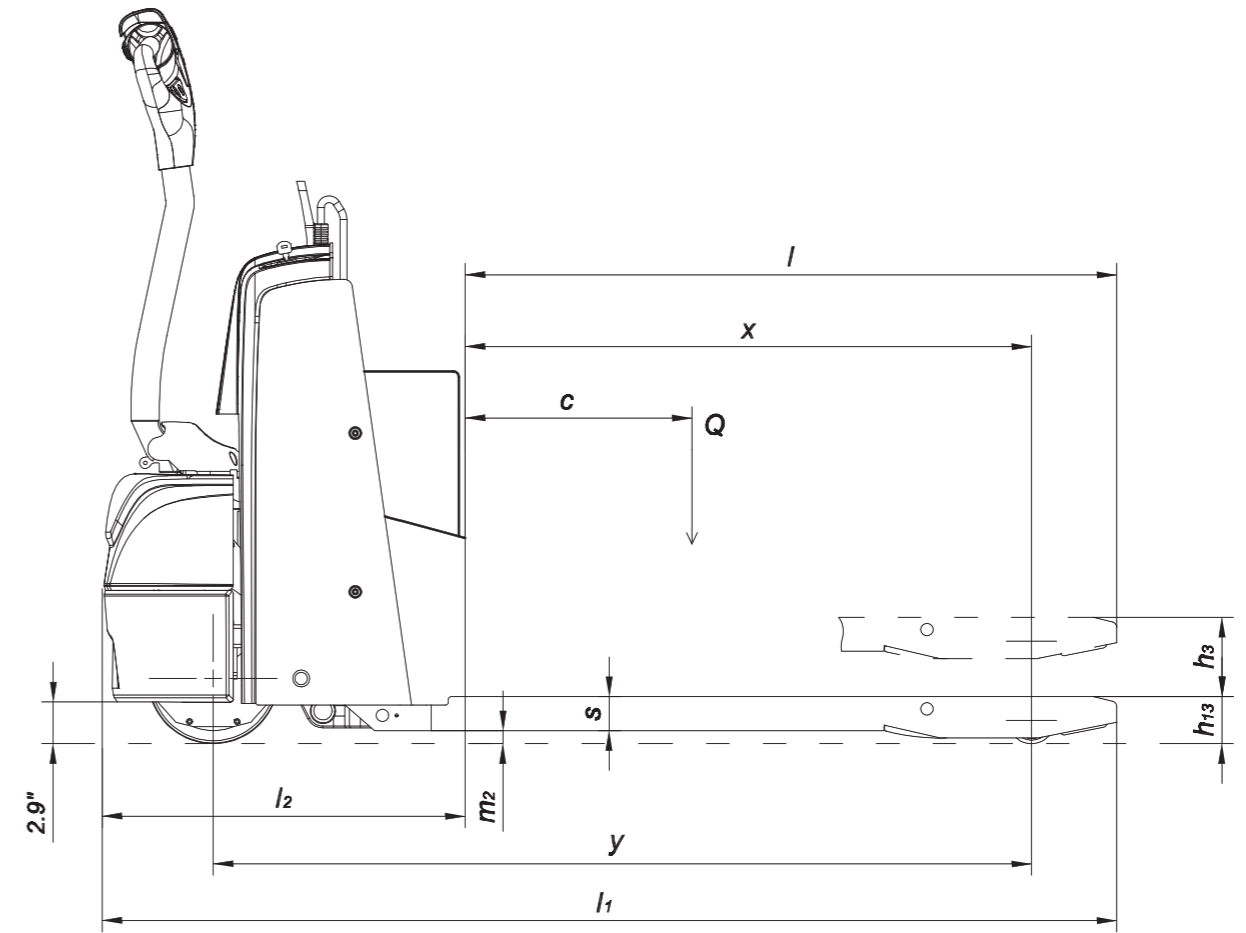

## Aisle Guide

### Aisle Requirement for Right Angle Stacking<sup>①</sup>

Fork Length (actual)	in(mm)	29.5(750)	33.5(850)	39.4(1000)	43.3(1100)	45.3(1150)	57.1(1450)	57.1(1450)	
		Load length (nominal fork length)							
	in(mm)	32(813)	36(914)	42(1067)	46(1168)	48(1219)	54(1372)	60(1524)	
Load Width	40(1016)	in(mm)	66.9(1700)	70.9(1800)	76.8(1950)	80.7(2050)	82.7(2100)	88.6(2250)	94.5(2400)
	44(1118)	in(mm)	68.7(1746)	72.7(1846)	78.6(1996)	82.5(2096)	84.5(2146)	90.4(2296)	96.3(2446)

<sup>①</sup>Add a minimum of 12in (300 mm) for maneuverability.